



WR300K SPEC SHEET V1.0

300M WiFi Wireless Router

1.Product Introduction

The WR300K is a WiFi 300M high-cost-performance wireless communication product, which can meet the needs of small networks such as offices and homes for quick, stable, secure, and easy Internet access. It operates at 2.4GHz with 802.11b/g/n and provides speeds up to 300Mbps. It is equipped with 3*10/100M adaptive Ethernet LAN interfaces for internal LAN connection, and 1*10/100M adaptive Ethernet WAN interface for wired broadband connection.

2. Product Image



3. Product Features

1) Industrial device design with built-in protections such as electrostatic discharge, surge, and fast transient pulses, easily adapts to various harsh environments, ensuring long-term stable and reliable operation.

2) Provides 802.11b/g/n WiFi 300M wireless access with high-gain antennas, covering up to 30 meters in open environments; also offers 10/100Mbps Ethernet access, supporting up to 16 concurrent users.

3) Supports WPA-PSK/WPA2-PSK, SSID hiding, and blacklist features to effectively safeguard user data security.

4) Rich status indicator lights, comprehensive status overview, and easily readable log system to monitor device operational status effortlessly.

5) Built-in quick setup wizard for easy broadband WiFi internet access without requiring specialized knowledge.

6) Continuous product updates, feature enhancements, and performance optimizations to adapt to various network environments and improve user experience.

4. Technical Specifications

Hardware configuration	
Main Chip	MT7628KN
Frequency	575MHz
Memory	8MB
Flash	2MB
Wireless Technology	802.11b/g/n 300Mbps MIMO technology
Device Interfaces	WAN*1 10/100Mbps adaptive Ethernet ports LAN*3 10/100Mbps adaptive Ethernet ports DC direct current power supply interface, suitable for power plug insertion with outer diameter of 4.0mm, inner diameter of 2.68mm, and length of at least 9.5mm.
Buttons	Reset button for restoring factory settings, long press for 5 seconds to restore factory settings
Indicators	Traffic light with red/green dual colors
Antennas	External 2.4G 5dBi stick antennas *4
Power	DC 5V/1A power supply with positive outside and negative inside
Operating/Storage	0°C ~ 40°C/-20°C ~ 70°C

Temperature	
Operating/Storage Humidity	5% to 90% (non-condensing)
Dimensions	183. *113. 3*31. 4mm
Weight	0. 5kg

WiFi Spec	
Frequency Range	802.11b/g/n:2.4~2.4835GHz
Channel	1、 2、 3、 4、 5、 6、 7、 8、 9、 10、 11、 12、 13
Modulation	802.11b: DSSS (DQPSK, DBPSK, CCK) 802.11g: OFDM (BPSK, QPSK,16-QAM) 802.11n: OFDM (BPSK, QPSK,16-QAM, 64-QAM)
Transmission Rate	11b up 11Mbps, 11g up 54Mbps, 11n up 300Mbps
Receiver Sensitivity	11b: $\leq -90 \pm 1.5 \text{dBm}$ @1Mbps, $\leq -84 \pm 1.5 \text{dBm}$ @11Mbps 11g: $\leq -86 \pm 1.5 \text{dBm}$ @6Mbps, $\leq -69 \pm 1.5 \text{dBm}$ @54Mbps 11n 20MHz: $\leq -85 \pm 1.5 \text{dBm}$ @MCS0, $\leq -67 \pm 1.5 \text{dBm}$ @MCS7 11n 40MHz: $\leq -82 \pm 1.5 \text{dBm}$ @MCS0,

	$\leq -64 \pm 1.5 \text{dBm @MCS7}$
Transmit Power	11b: $\geq 20 \pm 1.5 \text{dBm @11Mbps}$ 11g: $\geq 20 \text{dBm} \pm 1.5 \text{dBm @54Mbps}$ 11n: $\geq 20 \text{dBm} \pm 1.5 \text{dBm @MCS7}$

Software Functions	
Working Mode	Routing mode
Number of connected users	16 Peoples
Management mode	English/Chinese web remote management
Status	-System status, interface status -User list -Blacklist
Network	-Network configuration: LAN、WAN
WiFi	WiFi switch\WiFi name\Encryption\WiFi password\ Hide WiFi\Protocol\Bandwidth\Channel\ Signal strength
系统管理	-Management Password -System Time -Upgrade/Reset: Restore Factory Configuration, Download Backup Configuration, Upload Restore

	Configuration, Local Upgrade -System Logs -Reboot: Immediate Reboot, Scheduled Reboot
Quick Setup	Internet Connection Type:-Wireless Configuration

5. Product dimension diagram(mm)

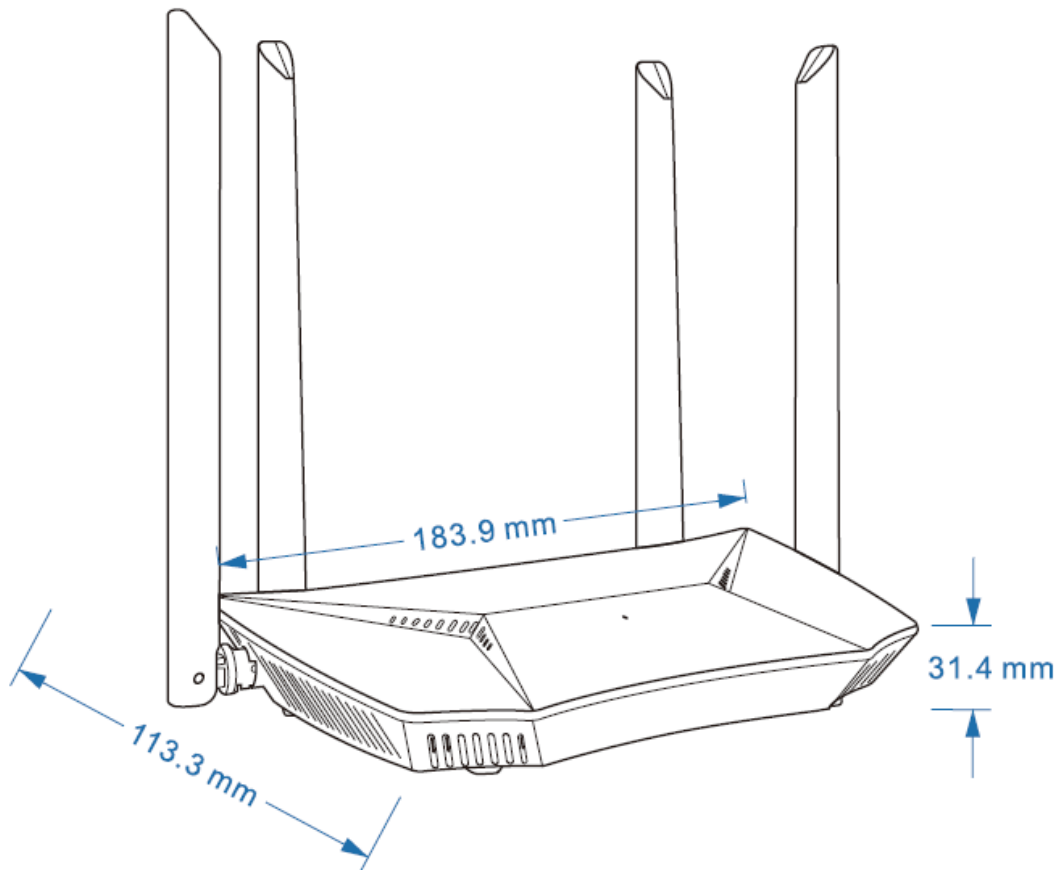

6. Packaging information

WR300K*1, DC 5V/1A Power adapter*1, Ethernet cable*1, user manual